



**Eclipse Series 1000 Disc Type Check Valves** are designed to prevent reverse flow of gas or air, however, they are not designed for tight shut-off. They are especially suited for use in distribution systems and industrial plants.

Series 1000 Valves are available in pipe sizes from 1/2" thru 8" (1/2" thru 2" available with Rc threads). The design of these valves allows high capacities at a pressure drop only slightly higher than that of a corresponding size pipe. Flows range from 280 cfh to 42,000 cfh depending on valve size selected. All valve sizes will operate properly with a minimum inlet pressure of 1.5" w.c. Maximum inlet and back pressures range from 7 to 70 psig depending on valve size (see capacity table on page 2).

Series 1000 Check Valves may be mounted either horizontally or vertically. If the valve is to be mounted vertically, the direction of flow must be up. The required minimum inlet pressure and the pressure drop thru the valve will increase with vertical mounting.

The simple design and rugged construction of these valves makes it possible for them to deliver years of uninterrupted service. A removable top cover allows easy access for inspection and for performing any maintenance that may be necessary without removing the valve from the line.

Maximum operating temperature for these valves is 200° F. When ordering, please specify the catalog number, pipe size, fluid (sp. gr.), inlet pressure and back pressure.

*Although leakage, if any, is negligible, check valves should not be considered equivalent to approved shut-off valves.*

# DISC TYPE CHECK VALVES

## SERIES 1000



1/2" Thru 1-1/2"  
Threaded Brass Body



2" Thru 4" Threaded  
Cast Iron Body



3" Thru 8" Flanged  
Cast Iron Body



### Threaded Body

1/2" thru 1-1/2" Brass

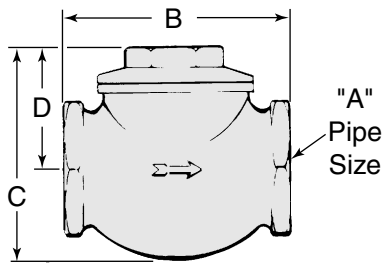

### Threaded Body

2" thru 4" Cast Iron

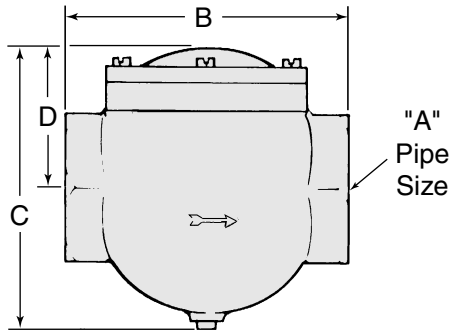

### Flanged Body

3" thru 8" Cast Iron

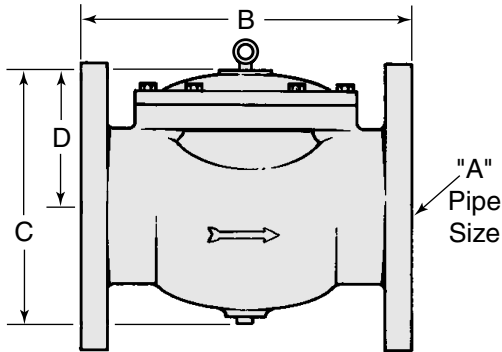

Note: Lifting eye is standard on 6" and 8" models only.

## Dimensions

Catalog Number	Assembly Number	Dimensions in Inches				Approx. Wt. in lbs
		A	B	C	D	
<b>Threaded Bodies*</b>						
1005 A	550088	1/2	3-1/4	2-3/4	1-3/4	1.5
1006 A	550092	3/4	3-1/4	2-3/4	1-3/4	1.5
1010 A	550096	1	3-5/8	3	2	2
1012 A	550100	1-1/4	3-15/16	3-1/2	2-1/4	2.5
1015 A	550104	1-1/2	4-3/8	4	2-5/8	3
1020 A	550108	2	5-7/8	5-1/2	2-3/4	9
1025 A	550116	2-1/2	6-5/8	6-5/8	3-5/8	11.5
1030 A	550124	3	6-7/8	6-7/8	3-3/8	13
1040 A	550132	4	8-3/8	8-1/2	4-1/2	24
<b>Flanged Bodies**</b>						
1030F-A	550148	3	8-1/2	7-1/2	3-3/4	29
1040F-A	550156	4	10-1/2	8-1/2	5	49
1060F-A	550164	6	16-1/4	13	6-1/4	125
1080F-A	550172	8	18-1/8	16-1/4	7-3/4	220

\* N.P.T. threads are standard. Rc threads are available in 1/2" thru 2" sizes by adding -1 to the assembly numbers listed above.

\*\* Flange hole patterns per ANSI B16.5, class 150

## Capacities

Catalog Number	C <sub>v</sub>	Flow*	Pressure Maximums**
<b>Threaded Bodies</b>			
1005 A	6.9	280	70
1006 A	12.3	500	70
1010 A	17.2	700	60
1012 A	34.5	1,400	50
1015 A	49.4	2,000	40
1020 A	81.3	3,300	30
1025 A	116.0	4,700	20
1030 A	177.0	7,200	15
1040 A	271.0	11,000	15
<b>Flanged Bodies</b>			
1030F-A	177.0	7,200	15
1040F-A	271.0	11,000	15
1060F-A	616.0	25,000	10
1080F-A	1035.0	42,000	7

\* SCFH of 0.6 sp.gr. gas @ 1/2" w.c. ΔP  
Higher flows available at higher ΔP

\*\*Maximum inlet and back pressure psig

**ECLIPSE™**  
Innovative Thermal Solutions

**Eclipse Combustion**

www.eclipsenet.com

ISO 9001 Registered