



Innovative Combustion Solutions Worldwide

GAS PRESSURE REGULATORS

Eclipse offers a line of gas regulators for industrial applications of natural, mixed, manufactured and liquefied petroleum gases or LP gas-air mixture. The regulators are categorized according to design:

Rubber Seat Poppet Type

These regulators are designed primarily for main burner and pilot load applications where precise control of tiny flows is an essential operation requirement. Housings are cast aluminum.

Straight Thru-Flow Type

The patented design of these low pressure regulators provides accurate, sensitive regulation. This design also allows high flow rates with minimum pressure drops.

These regulators should not be used:
1) where the inlet pressure will be ten times greater than the outlet pressure, and 2) as tight shut-off valves.

Outlet pressures may be varied by changing the diaphragm spring. Housings are aluminum for sizes through 3", and iron for the 4" size.

Double Diaphragm Type

The RS Series is designed primarily for main burner and pilot load applications. They are ideally suited for industrial heaters and boilers. The double diaphragm balanced valve design prevents the inlet pressure from acting on the valve. Housings are aluminum.

Positive Shut-Off Type

The 325-5A is a lever acting regulator with an aluminum housing. It features a high leverage valve linkage to deliver positive dead end lock-up and precise regulation control from full flow down to tiny pilot flows. The 325-5A can be ordered with various springs to accommodate outlet pressures from 4" w.c. up to 2 psi.

Rubber Seat Poppet Type
Model RV 48

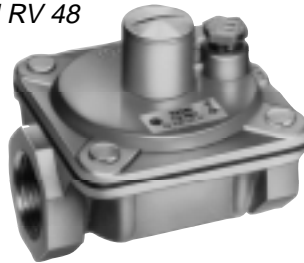

Straight Flow-Thru Type
Model RV 131



Double Diaphragm Type
Model R400S

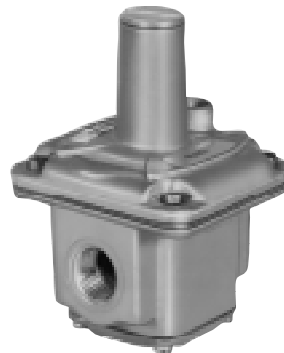

Positive Shut-Off Type
Model 325-5A



Specifications

Model	Pipe Size, Inches	Max. Inlet, PSI	SCFH Flow at Various Pressure Drops (Natural Gas at 0.64 specific gravity)									Maximum Emergency PSI ¹	Temp. Limits, °F		Mounting Position	Outlet Pressure Range ² ("w.c.)	
			0.3"	0.7"	0.8"	0.9"	1"	2.5"	4"	8"	16"		28"	Min.			Max.
Rubber Seat Poppet Type—CGA Listed, AGA Certified																	
RV12LT	1/8	1/2	15	23	24	26							2.5	-40	275	Any	2.8 to 5.2
RV20VL	1/4	1/2	30	46	49	52	55						2.5	+32	225	Any	2.8 to 5.2
RV20VL	3/8	1/2	30	46	49	52	55						2.5	+32	225	Any	2.8 to 5.2
RV48	1/2	1/2	130	199	212	225							2.5	+32	225	Any	5 to 12
Straight-Thru Flow Type—CGA Listed; AGA Certified for 1/2 PSIG																	
(AGA certified for the ranges shown in bold numbers, with the outlet pressures shown as standard.)																	
RV 52	1/2	1/2	262	400	427	453	478	756	956				3	-40	205	Any	5 to 12
	3/4	1/2	262	400	427	453	478	756	956				3	-40	205	Any	5 to 12
RV 53	3/4	1/2	375	573	612	650	684	1081	1369				3	-40	205	Any	5 to 12
	1	1/2	375	573	612	650	684	1081	1369				3	-40	205	Any	5 to 12
RV 61	1	1	675	1004	1073	1138	1200	1897	2464				5	-40	205	Any	5 to 12
	1-1/4	1	675	1004	1073	1138	1200	1897	2464				5	-40	205	Any	5 to 12
RV 81	1-1/4	1	1350	2062	2204	2339	2465	3897	4929				5	-40	205	Upright	5 to 12
	1-1/2	1	1350	2062	2204	2339	2465	3897	4929				5	-40	205	Upright	5 to 12
RV 91	2	1	2100	3208	3429	3637	3834	6062	7668				5	-40	205	Upright	5 to 12
	2-1/2	1	2100	3208	3429	3637	3834	6062	7668				5	-40	205	Upright	5 to 12
RV 111	2-1/2	1	4750	7256	7757	8227	8572	13,553	17,161				5	-40	125	Upright	5 to 12
	3	1	4750	7256	7757	8227	8572	13,553	17,161				5	-40	125	Upright	5 to 12
RV 131	4	2	8200	12,525	13,390	14,202	14,971	23,672	29,942				15	-40	125	Upright	5 to 12
Double Diaphragm Type																	
R400S	1/2	5	105	160	171	182	192	304					12.5	-40	205	Any	4 to 12
R500S	3/4	5	240	367	392	416	438	693	876				12.5	-40	205	Any	4 to 12
Positive Shut-Off Type																	
325-5A	1/2	10	70	107	114	121	128	202	255	361	509	673	65	-40	205	Any	4 to 12
	3/4	10	70	107	114	121	128	202	255	361	509	673	65	-40	205	Any	
	1	10	70	107	114	121	128	202	255	361	509	673	65	-40	205	Any	

 = At these flows and regulator pipe sizes, velocity pressures exceed 0.5. To avoid excessive pressure drops, use larger pipe upstream and downstream of the regulator. Contact your Eclipse representative for assistance.

¹ Maximum inlet pressures that the regulator can contain. Depending on model, some internal parts may be damaged.

² For springs supplied as standard. See "Optional Springs" chart for availability of other springs.

Optional Springs

Model	Pressure Range "w.c.	Part No.	Spring Color
RV52	1 to 3.5	12295	Brown
RV53		12296	
RV61		12297	
RV81		12298	
RV91		12299	
RV111		12300	
RV131		CON	
RV61	10 to 22	14314	Red
RV81		12316	
RV91		12317	
RV111		12319	
RV131		CON	
325-5A		10928-2	
325-5A	15 to 30	10928-3	Yellow
325-5A	1 to 2psi	10928-4	Tagged

Note: If the outlet pressure can be provided by two different springs, select the higher outlet pressure

Sizing and Selection

- 1) Determine the following:
 - a) Inlet pressure to regulator
 - b) Outlet pressure required from regulator
 - c) SCFH required through regulator
 - d) Desired size of regulator
- 2) Subtract outlet pressure from inlet pressure and divide by two. Use this figure as the maximum allowable pressure drop when sizing the regulator.
- 3) In the Specifications table above, find the column closest to, but not exceeding, the maximum allowable pressure drop.
- 4) Read down to find a regulator of the correct pipe size with a flow closest to, but not less than, the required SCFH.

Dimensions

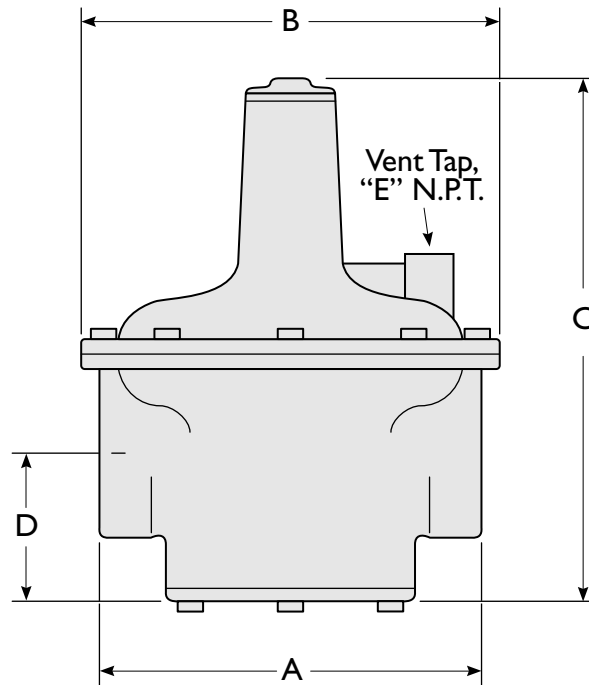

Catalog Number	Part Number	Pipe Size	Dimensions, In Inches					Approx. Ship. Wt. (Lbs.)
			A	B	C	D	E	
RV12LT	17127-1	1/8	1-11/16	1-3/8	1-11/16	3/8	—	1
RV20VL	15027	1/4	2-3/8	1-3/4	2-1/8	1/2	5/16*	1
RV20VL	17127-6	3/8	2-3/8	1-3/4	2-1/8	1/2	5/16*	1
RV 48	12271	1/2	3-3/8	3	2-3/4	3/4	1/8	1-1/4
RV 52	12274 12276	1/2 3/4	3-3/16	3-1/4	5-1/16	1-1/2	1/8	1-1/4
RV 53	12277 12278	3/4 1	3-5/8	3-7/8	5-13/16	1-5/8	1/8	1-1/2
RV 61	12279 12280	1 1-1/4	4-3/8	5-7/16	6-7/16	1-5/8	1/8	2-1/2
RV 81	12282 12284	1-1/4 1-1/2	6	7	8-5/8	2-5/8	1/4	5-1/4
RV 91	12285 12286	2 2-1/2	6-1/2 7-1/8	9-1/8 9-1/8	10-13-16 10-1/2	2-3/8 2-7/16	1/4 1/4	9 9
RV 111	12288 12290	2-1/2 3	9	13-7/16	15-1/16	3-7/16	1/4	20
RV 131	Contact Factory	4	13-7/8	18	23-1/4	5-1/16	3/4	127
R400S	17127-8	1/2	2	2	3-1/4	15/16	1/8	1/2
R500S	17127-9	3/4	3	3-1/8	4-11/16	1-3/16	1/8	1
325-5A	10866 10888 10897	1/2 3/4 1	5-7/8	5-7/16	5-1/4	15/16	3/8	2

* 5/16"-24 THD for 1/8" O.D. tube connector, p/n 13204.



Eclipse Combustion
www.eclipsenet.com